



intelliGen Retrofit Kits for Beacon II & QRC Controller

Retrofit Kits

July 2023

Part No. 25011001

Installation and Operation Manual



Table of Contents

intelliGen Components

intelliGen Board (iRC) Layout	3
intelliGen User Interface (iRCUI) Layout	4
IntelliGen Remote Access Cards (iWC, iLC)	4

Installation & Wiring

Installation Preparation	5
Low Profile Instructions	6-7
Center Mount Instructions	8-10
Medium Profile Instructions.....	11-14
High Profile Instructions.....	15-16
IntelliGen System Start Up	17
Retrofit Kit Parts List	18



Scan QR code to view the manual online



The IntelliGen™ Refrigeration Controller Retrofit Kits cover by this installation and operation manual are designed to replace the Beacon II™ Refrigeration Controller and Quick Response Controller™ (QRC) in the Heatcraft unit cooler refrigeration equipment installed in the field. The kits are designed to retrofit the Beacon II and QRC controllers in the Low Profile, Center Mount and Low Velocity Center Mount, Medium Profile and High Profile Large Unit Coolers to the IntelliGen controller. The unit cooler images below are shown with the IntelliGen controller installed.

Low Profile

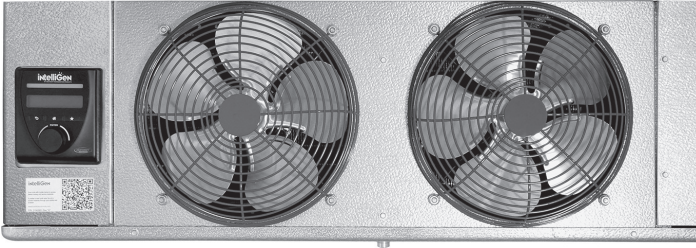

Center Mount



Medium Profile

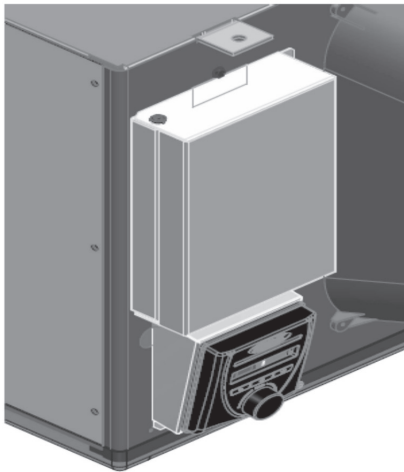

Large Unit Cooler



The retrofit kits are designed to minimize field installation labor and new components needed. The IntelliGen controller shares the same temperature sensors, EXV and connection plugs as used for the existing Beacon II and QRC controllers. The temperature sensors, EXV, EXV cable, pressure transducer and cable could be re-used for the IntelliGen control retrofit. The Beacon II and QRC control systems use a 139.7 PSIA pressure transducer. The IntelliGen controller can reuse this existing pressure transducer with new configuration and setup. On the local user interface, go to BOX SETTING menu to select the pressure transducer type, BOX SETTING/ TRANSDUCER TYPE/28911201 (139.7PSIA).

intelliGen Board (iRC) Layout

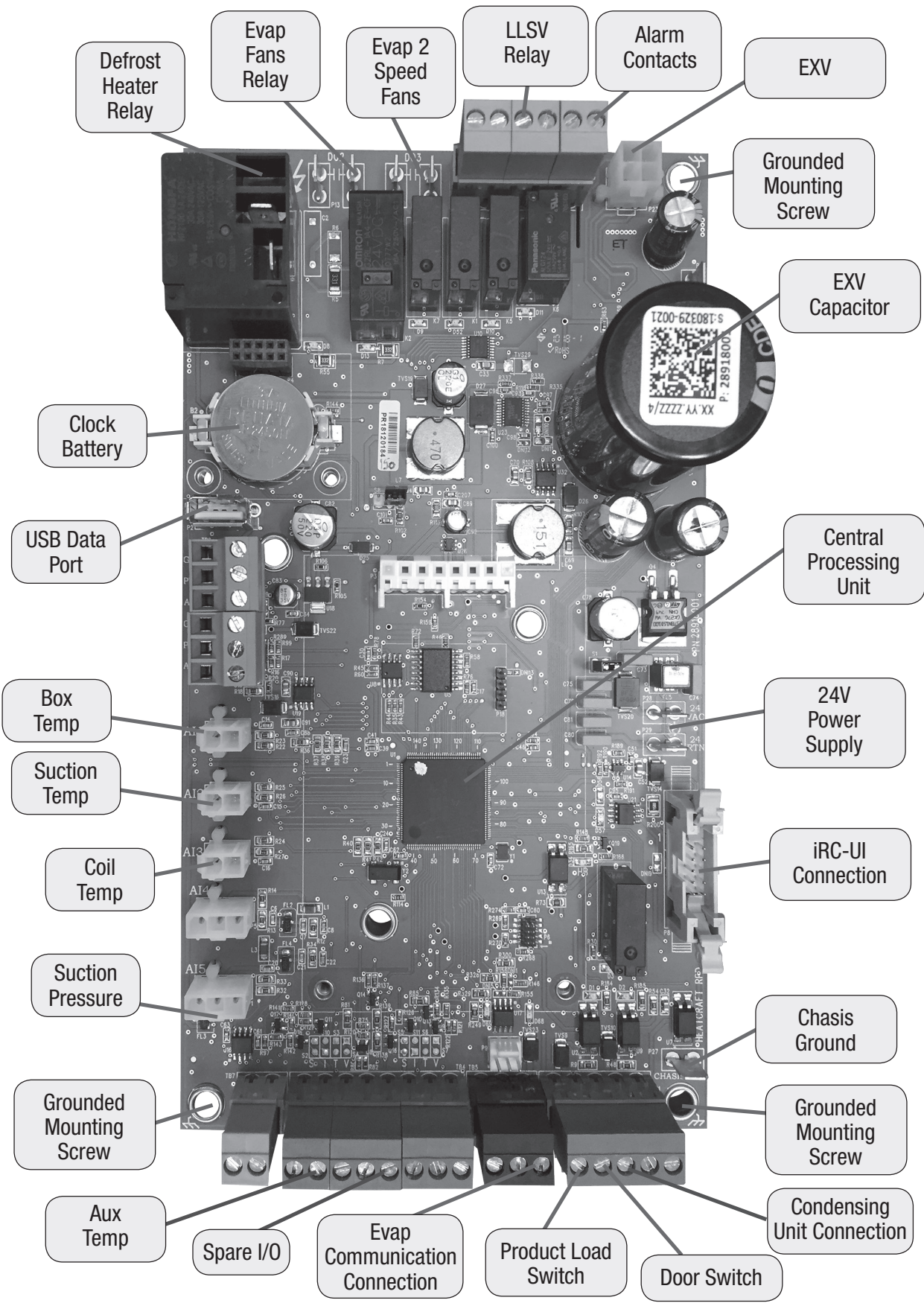

intelliGen User Interface (iRCUI) Layout

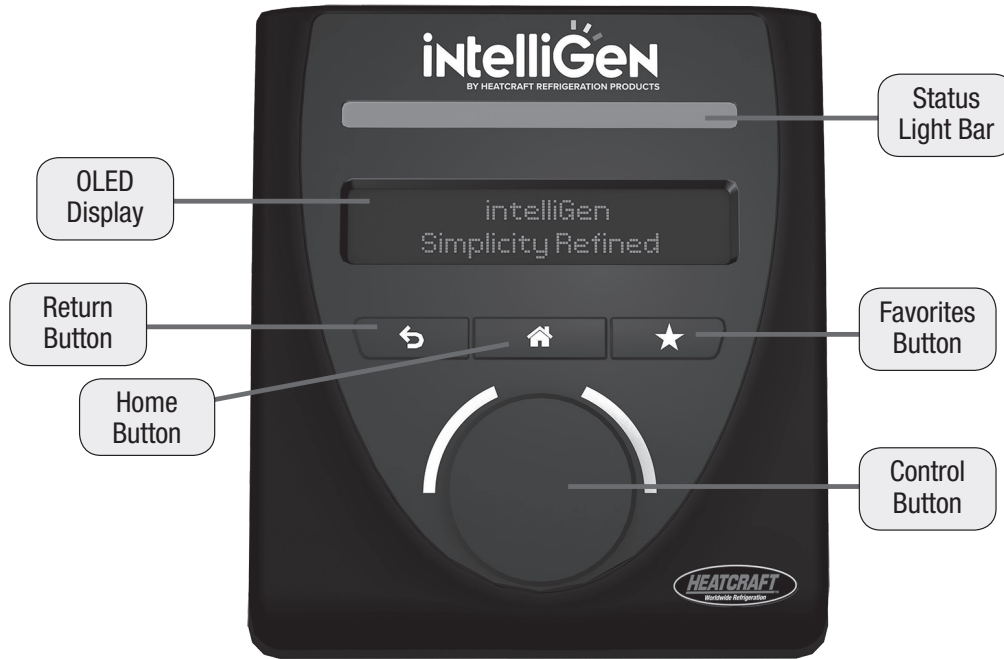

intelliGen Remote Access Cards

MULTI-SYSTEM CONTROL CARD - MSC WEBSERVER CARD - iWC

INTEGRATION CARD - iIC

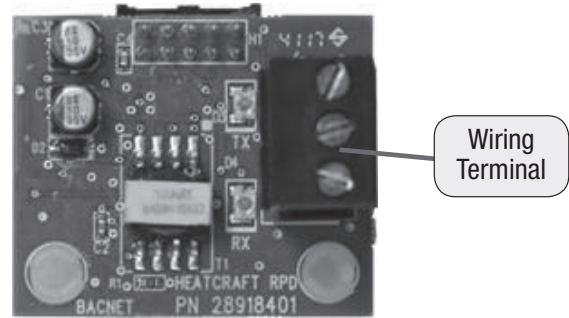
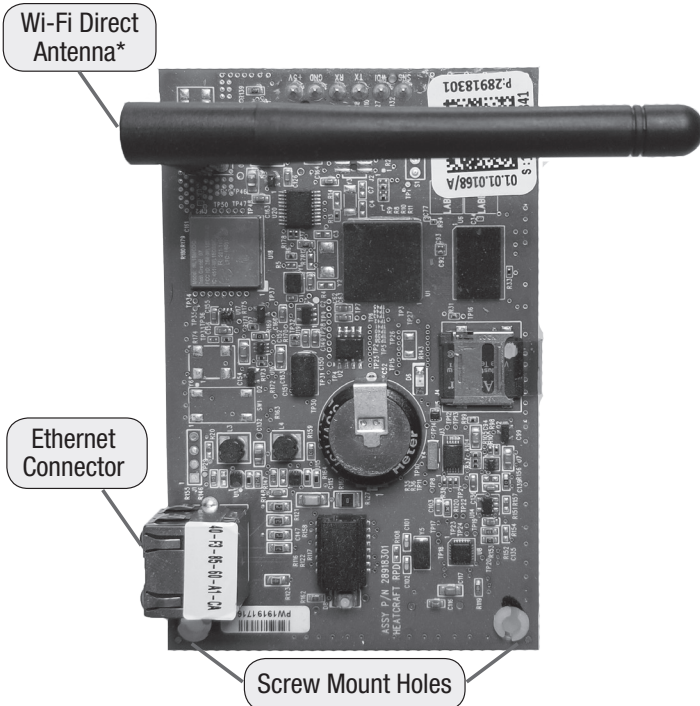

Scan the QR code or visit www.intelliGencontrols.com/resources to view the manual.



LEGEND

Abbrev. Name	Long Name
EV	Evap/Evaporator
SP	Set-Point
AUX	Auxiliary
TEMP	Temperature/Temp
CALIB	Calibration
EXV	Electronic Expansion Valve
CU	Condensing Unit
COMP	Compressor
CXN	Connection
LL	Lead-Lag

NOTE: Refer to iWC & MSC Installation & Operation Manual (H-IM-iWC/MS) for installation and maintenance instructions.
* MSC card comes with Wi-Fi Direct antenna and the iWC webservice card does not come with Wi-Fi Direct antenna.

Preparation for Retrofit

Tools Needed:

- 5/16" nut driver
- 7/16" wrench
- 5/8" wrench
- Screw drivers

Pump Down and Power Off the Unit Cooler

1. Put the existing Beacon II and QRC Unit Cooler into service mode and pump down the unit.
 - 1.1. Open the unit cooler end panel for access to the Beacon II or QRC controller
 - 1.2. Press the "FORCE SERVICE" button twice on the control board to put the unit cooler into service mode

Pump Down and Power Off the Unit Cooler (cont.)

- 1.3. The LED display on the control board should display "SEr" as the unit cooler is in service mode
- 1.4. Wait for the system to pump down and shut off. It would take about 5 minutes.

2. Disconnect power to the unit cooler

See *Beacon II Refrigeration Systems Installation and Operation Manual* for more details (H-IM-79G, Part No. 25001401).

It is available at www.heatcraftprd.com/resources/literature/

Select I&O Manual for Document Type and Controls and Other Products for Product Category to find the manual.



Quick Response Controller Board

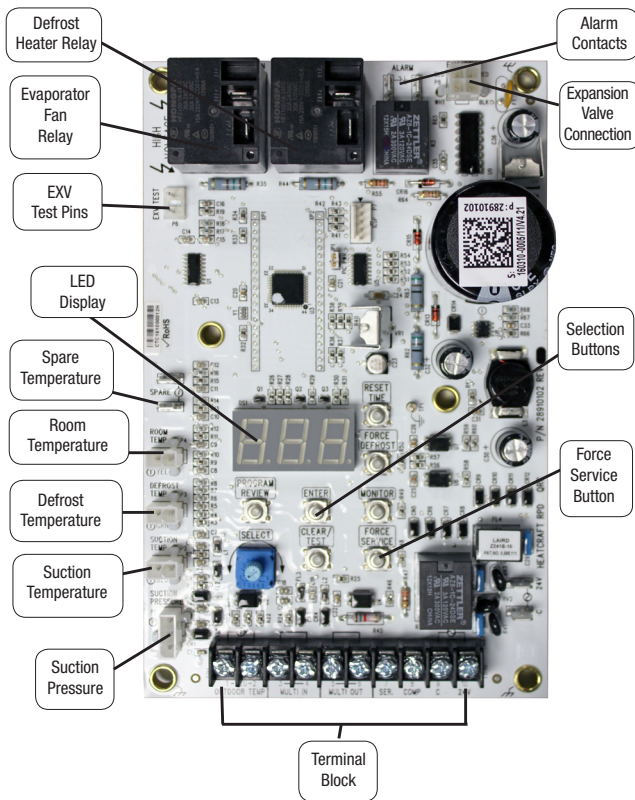

Beacon II™ Board

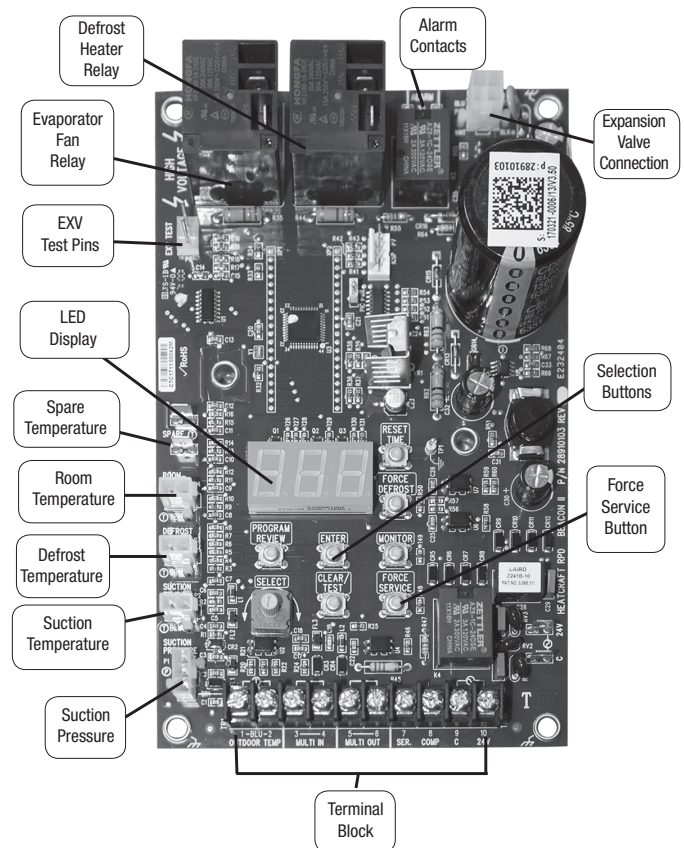

Pressure Transducer Configuration After intelliGen Installation

The new intelliGen controller supports 300 psia and 139.7 psia pressure transducer. The existing pressure transducer for Beacon II and QRC (139.7 psia) can be reused for the intelliGen system. Setup is required in the intelliGen to use the existing pressure transducer.

- Configuration from local user interface BOX SETTING/TRANSDUCER TYPE/28911201 (139.7PSIA).

- Configuration from the webserver page (if iWC webserver card or MSC multi-system control card is used.)

1. Open the webserver page on a computer or smart device by entering the system IP address in a web browser's address bar
2. Open the UNITS tab and select the unit cooler for setup
3. Scroll down the individual unit cooler's webserver page to the PRESSURE TRANSDUCER section
4. Select the transducer 28911201 (139.7PSIA)

Low Profile (LOP) Unit Cooler Retrofit Kit Instructions:

1. Use 5/16" nut driver. Remove the 2 end panel screws. See image LOP-1.

Pro Tip: We recommend taking a picture of the Beacon II/QRC wiring before disassembly for use as additional reference when wiring the intelliGen board later on.

2. Unplug the sensor wires and cables from the Beacon II or QRC control board
3. Use 5/16" nut driver. Remove the 2 screws from the Beacon II or QRC control board mounting bracket. See image LOP-2.
4. Remove Beacon II/QRC control board and bracket assembly from the equipment
5. Mount the intelliGen control assembly to the front face of the unit. See image LOP-3.

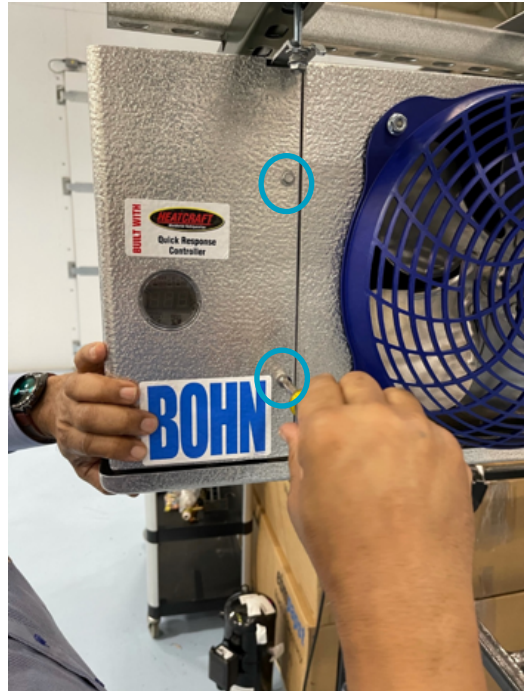

LOP-1

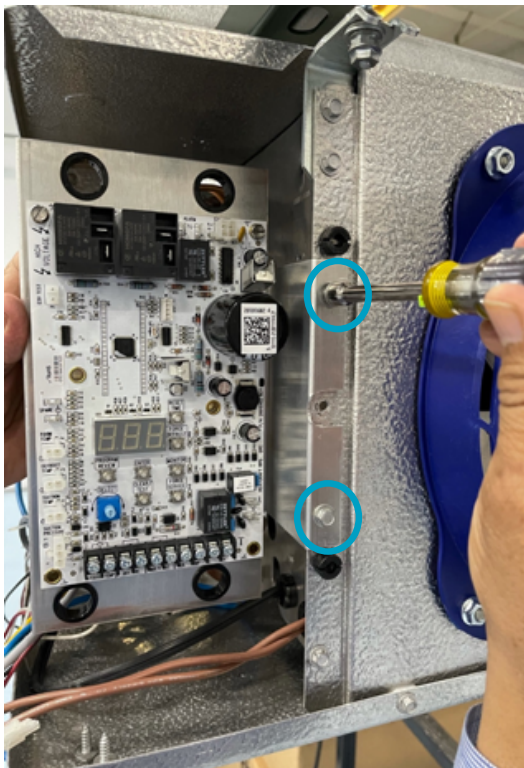

LOP-2



LOP-3

Low Profile (LOP) Unit Cooler Retrofit Kit Instructions: (cont.)

6. Mount the IntelliGen control assembly to the 2 pre-drilled screw holes on the coil end-plate. See image LOP-4.
 - 6.1. Use 5/16" nut driver; an extended, magnetic tipped nut driver or 5/16" drill attachment can make mounting easier.
7. Remove the two screws on the front face of the unit so that the iRCUI can be swung open to expose the iRC for wiring.
8. Route the wires and cables through the wiring routing holes on the new mounting bracket
 - 8.1. Temperature sensor wires
 - 8.2. EXV cable
 - 8.3. Pressure transducer cable
 - 8.4. High voltage wires
9. Plug all the wires and cables onto the IntelliGen control board

Pro Tip: Use the wiring aide label on the iRC mounting bracket to assist with proper wiring.

10. Plug in the IRCUI serial cable between the IntelliGen control board and the UI board. See image LOP-5.
11. Attach appropriate wiring diagram included with the kit to the cover bracket for later reference.
12. Review all wiring to ensure correct installation.
13. Close the iRCUI panel
14. Put on the new end panel with hole for iRCUI and tighten with 2 screws on the front
 - 14.1. Use 5/16" nut driver
15. The completed Low Profile retrofit assembly should look like image LOP-6 below.

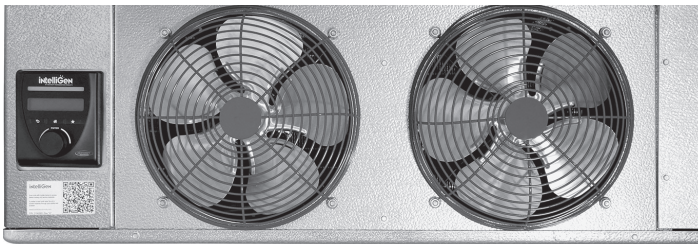

LOP-6

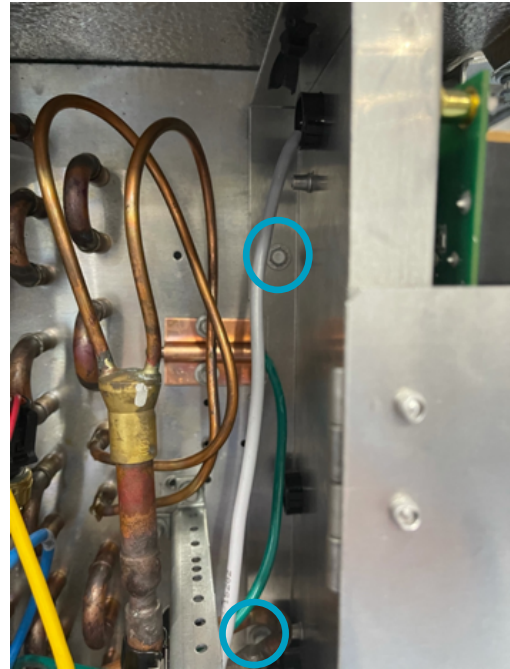

LOP-4



LOP-5

16. Restore power to the unit cooler.
17. See "IntelliGen System Start Up" section to continue the startup process

Center Mount (CM) and Low Velocity Center Mount (LVCM) Unit Coolers Retrofit Kit Instructions:

1. Remove the Beacon II/QRC board cover. See image CM-1.



CM-1

Pro Tip: We recommend taking a picture of the Beacon II/QRC wiring before disassembly for use as additional reference when wiring the IntelliGen board later.

2. Disconnect all wires/harnesses from the Beacon II/QRC board.
3. Remove screws from both end panels and remove the panels. (7 screws in total) See image CM-2.

Pro Tip: Dropping the drain-pan can make removal of these parts easier.



CM-2

Center Mount (CM) and Low Velocity Center Mount (LVCM) Unit Coolers Retrofit Kit Instructions: (cont.)

4. Mount the iRC board and bracket to the top-left of the unit. Attach with two #12 x 5/8 screws using 5/16" nut driver. See image CM-3.
iRC board will be facing down towards the ground if bracket is mounted properly.

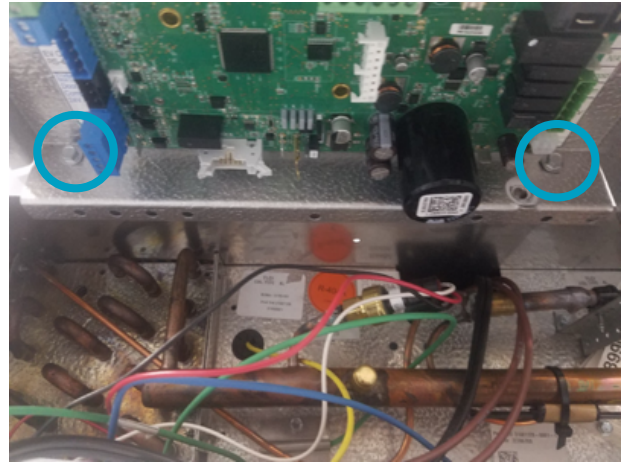

CM-3

5. Connect all sensors and control wires to the iRC board.
6. Attach captive fasteners to IRC bracket to help secure the back panel.
7. Mount the end panel to the right half of the unit. The top of this panel has a flange which fits over the top form of the unit, and the bottom of this panel sits inside the drain pan. Attach using four #12 x 5/8 screws. See image CM-4.
8. Mount the iRCUI with mounting bracket using three #12 x 5/8 screws. See image CM-5.



CM-4

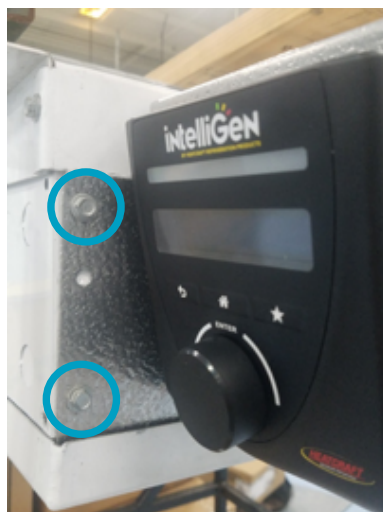

CM-5



Center Mount (CM) and Low Velocity Center Mount (LVCM) Unit Coolers Retrofit Kit Instructions: (cont.)

9. Connect the ribbon cable to the iRCUI and the iRC.
See image CM-6.
10. Attach appropriate wiring diagram included with the kit to the cover panel for later reference.
11. Mount the iRC cover panel using two #12 x 5/8 screws.
12. The completed Low Profile retrofit assembly should look like below. See image CM-7.

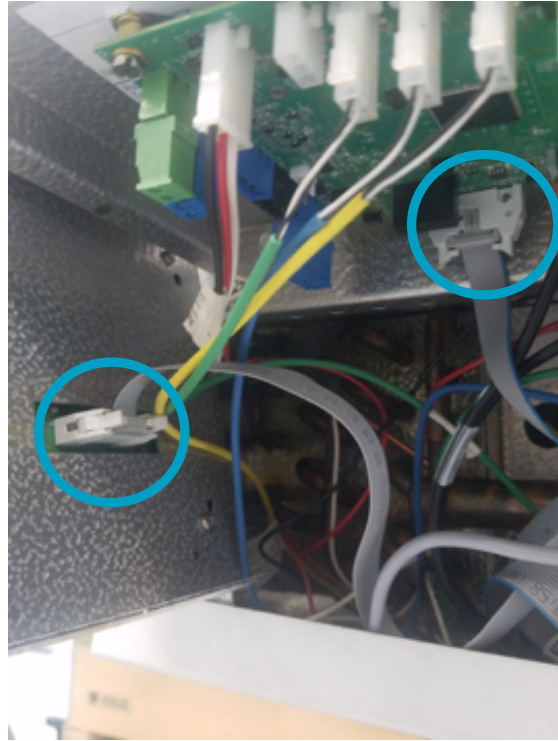

CM-6

13. Restore power to the unit cooler
14. See “intelliGen System Start Up” section to continue the startup process



CM-7

Medium Profile (MP) Unit Cooler Retrofit Kit Instructions:

Tools Needed:

- 5/16" nut driver
- 7/16" wrench
- 5/8" wrench
- Phillip head screwdriver

Installation Instruction:

1. Remove the Header End Panel screws and the end panel
 - 1.1. Use 5/16" nut driver
2. Remove the Beacon II or QRC control box cover on the front of the unit. See image MP-1.

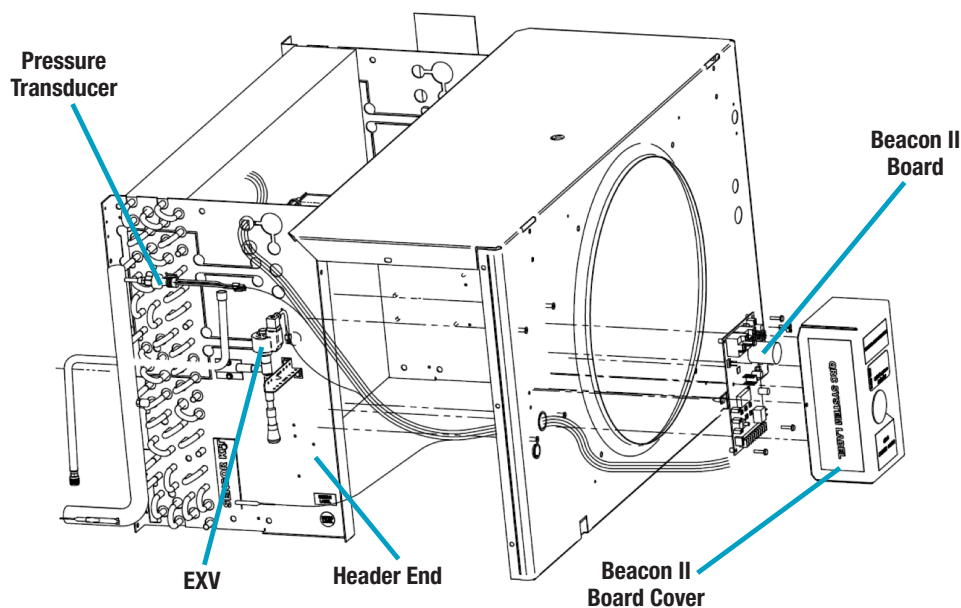

MP-1

Pro Tip: We recommend taking a picture of the Beacon II or QRC wiring before disassembly for use as additional reference when wiring the IntelliGen board later on

3. Unplug the sensor wires and cables from the Beacon II or QRC control board
4. Unscrew and remove the Beacon II or QRC control board

Medium Profile (MP) Unit Cooler Retrofit Kit Instructions: (cont.)

5. Start IntelliGen control mounting. The finish assembly looks like below. See image MP-3.

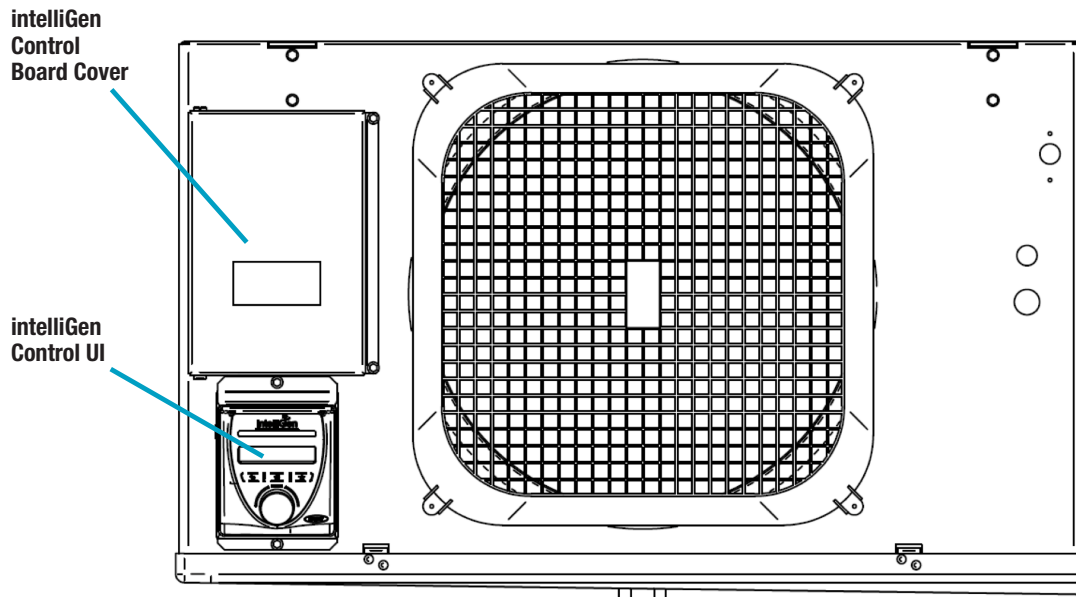

MP-3

Medium Profile (MP) Unit Cooler Retrofit Kit Instructions: (cont.)

6. Screw on the control board cover bracket and control board cover assembly. See image MP-4.
7. Close the control board cover and hold close with one of the screw on the left side of the cover.

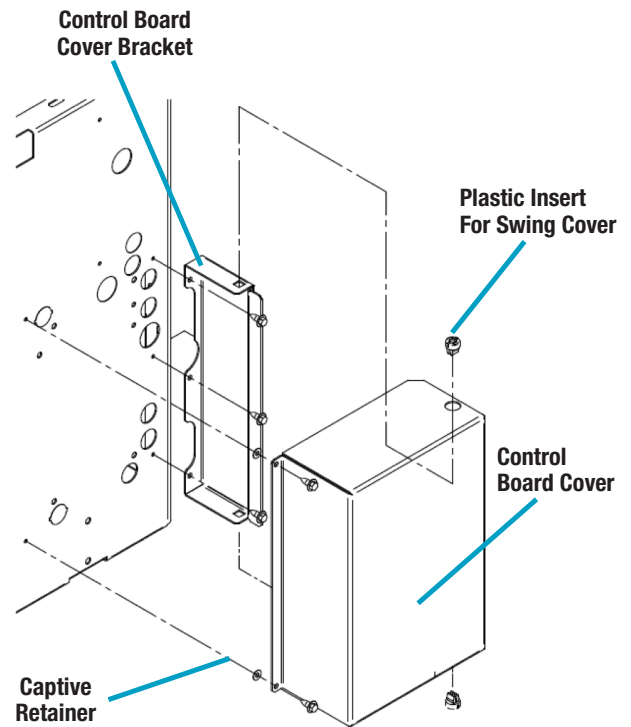

MP-4

8. Place the IntelliGen UI mounting bracket on the unit and above the control board cover (unit turned upside down). Align the UI bracket center and above the control board cover and mark the screw holes for mounting. See image MP-5.

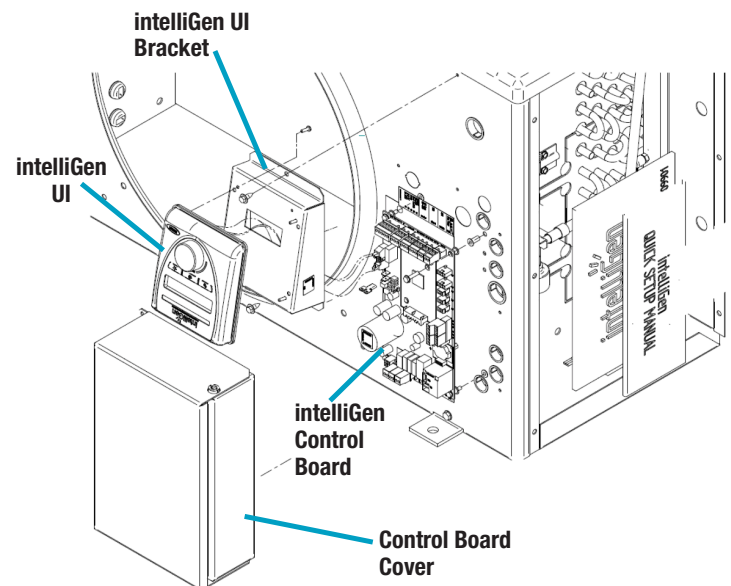

MP-5

9. Drill two screw holes on the markings for screw mounting of the IntelliGen UI assembly (or use self-tapping screws to mount the bracket after STEP 8).
10. Drill a 1" hole in between the two IntelliGen UI mounting holes.

Medium Profile (MP) Unit Cooler Retrofit Kit Instructions: (cont.)

11. Plug in the IntelliGen UI cable on the back of the IntelliGen UI assembly and insert the cable through the 1" hole.
12. Screw mount the IntelliGen UI assembly to the two mounting holes.
13. Swing open the Control Board Cover by removing the holding screw.
14. Apply the IntelliGen control board terminal layout label onto the Beacon II or QRC control board mounting area. Align the upper right mounting hole on the label to the upper right control board mounting hole.
15. Screw the main IntelliGen control board over the terminal layout label. The terminal identifications should be aligned with the terminals on the control board. Use sheet metal screws to tighten the control board on the two bottom mounting holes.
16. Plug all the wires and cables onto the IntelliGen control board.
17. Route and connect the IntelliGen UI cable to the IntelliGen main control board.
18. Check all the wires and cables for secure connections.
19. Attach appropriate wiring diagram included with the kit to the inside of the Control Board Cover Panel and the Header End Panel for future reference.

Pro Tip: Use the Beacon II wiring picture you took earlier for additional reference.

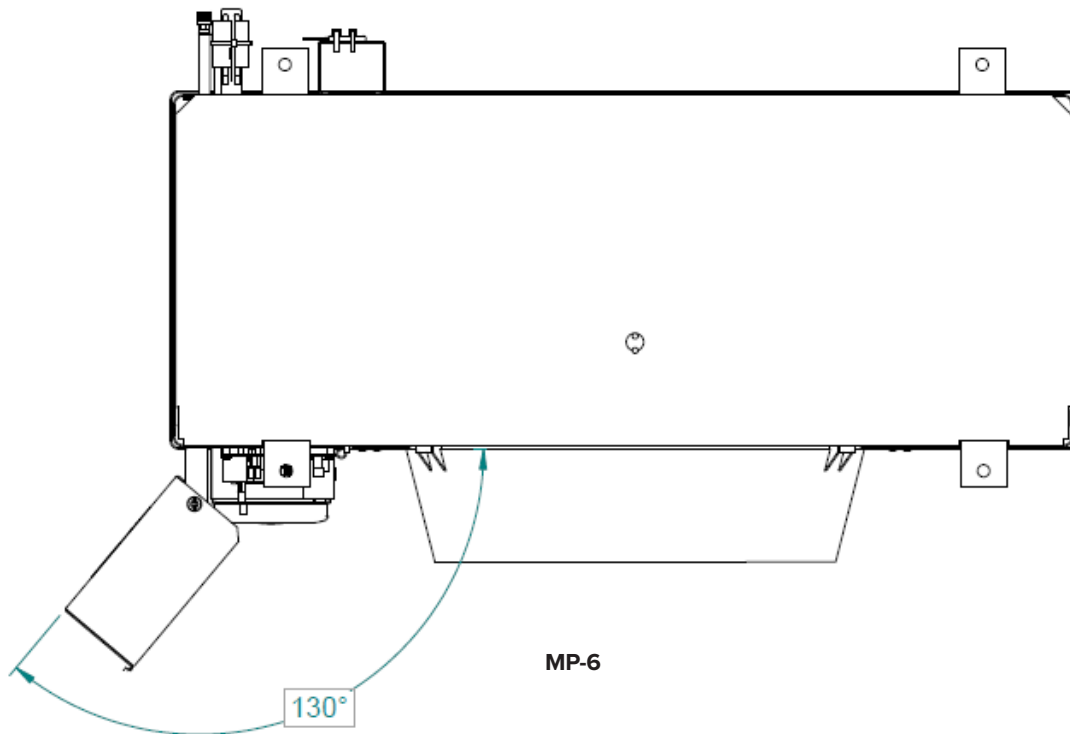

20. Close the control board cover over the IntelliGen control board and tighten with two screws. See image MP-6.
21. Put on the HEADER END PANEL and tighten with screws.
22. Restore power to the unit cooler.
23. See "IntelliGen System Start Up" section to continue the startup process.

High Profile Large Unit Cooler (LUC) Retrofit Kit Instructions:

1. Remove the end panel screws and the end panel at the HEADER END
 - 1.1. Use 5/16" nut driver
2. Unplug the sensor wires and cables from the Beacon II control board. See image LUC-1.
3. Unscrew and remove the Beacon II control board

Pro Tip: We recommend taking a picture of the Beacon II/QRC wiring before disassembly for use as additional reference when wiring the IntelliGen board later on.

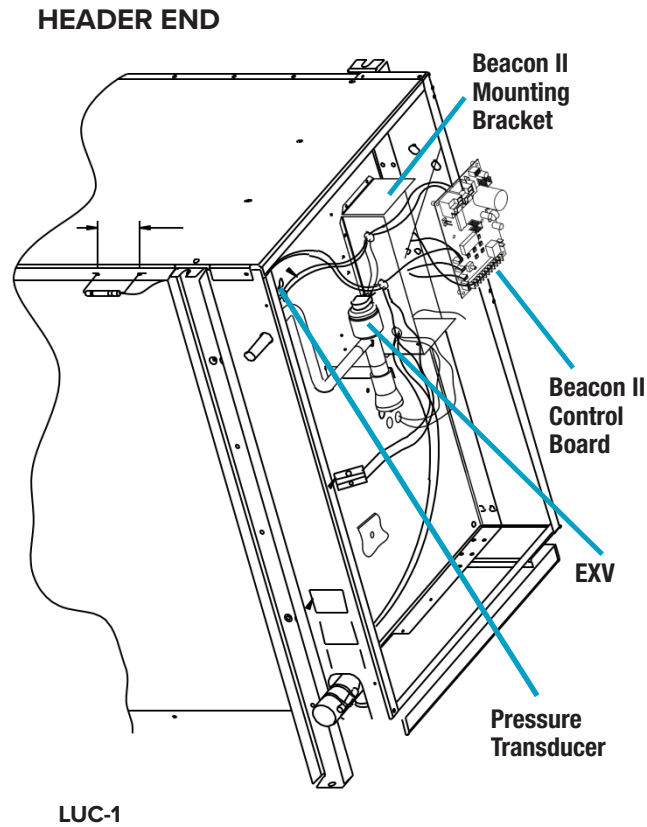

High Profile Large Unit Cooler (LUC) Retrofit Kit Instructions: (cont.)

4. Screw the main IntelliGen control board to the bracket area
5. Plug all the wires and cables onto the IntelliGen control board

Pro Tip: Use the Beacon II wiring picture you took earlier for additional reference.)

6. Place the IntelliGen UI mounting bracket on the lower left front of the unit and align bracket with unit as shown on the diagram below and mark the screw holes for mounting. See image LUC-4.
7. Drill two screw holes on the markings for screw mounting of the IntelliGen UI assembly (or use self-tapping screws to mount the bracket after STEP 10)
8. Drill a 1" hole in between the two IntelliGen UI mounting holes
9. Plug in the IntelliGen UI cable on the back of the IntelliGen UI assembly and insert the cable through the 1" hole
10. Screw mount the IntelliGen UI assembly to the two mounting holes
11. Route and connect the IntelliGen UI cable to the IntelliGen main control board
12. Check all the wires and cables for secure connections
13. Attach appropriate wiring diagram included with the kit to the inside of the HEADER END PANEL for later reference.
14. Put on the end panel and tighten with screws
15. The completed Large Unit Cooler retrofit assembly should look like image to the right. See image LUC-5.
16. Restore power to the unit cooler
17. See "IntelliGen System Start Up" section to continue the startup process

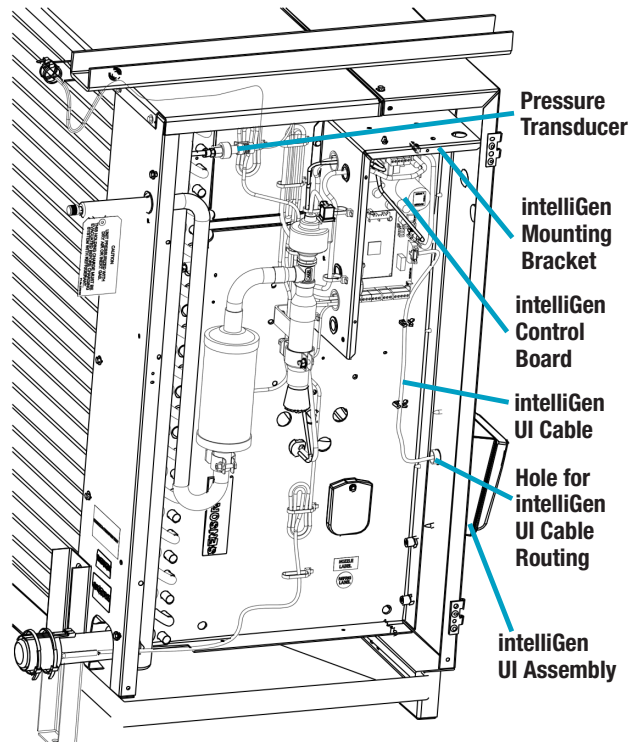

LUC-3

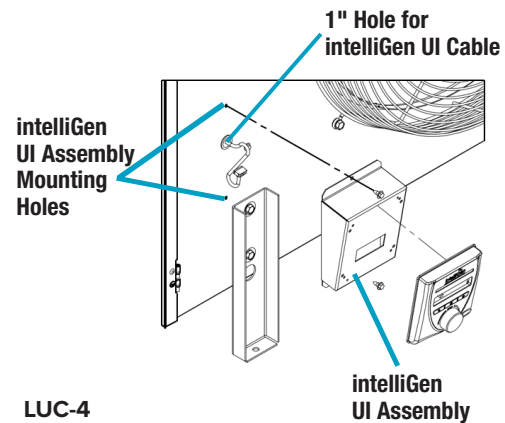

LUC-4

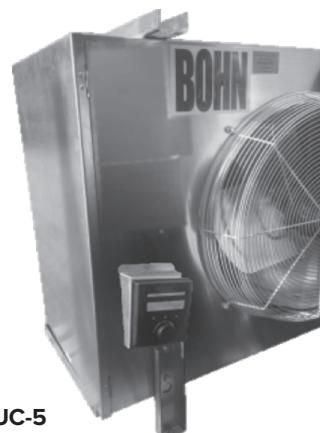

LUC-5

1. Follow the intelliGen “QUICK START GUIDE” to start up the system
2. For remote access installation of the webserver card (iWC) the Multi-system Control Card (MSC) or the integration card (iC)
 - 2.1. See the remote access section of the intelliGen Installation and Operation Manual
3. For diagnostics and troubleshooting of the intelliGen system, see Diagnostics & Troubleshooting Section of the intelliGen I&O manual
4. To find all intelliGen resources, including installation & operation manuals, technical bulletins, brochures, maintenance, troubleshooting information and more, simply scan the QR code or use the link below.

www.intelliGencontrols.com/resources





Retrofit Kits Part Number List

Model Family	Defrost Type	Voltage/Phase	Model Size	Color Finish	Retrofit Kit Part #	
Low Profile (LOP)	Air & Electric	115/1 208-230/1	All	Stucco	89730101	
				White	89730102	
Center Mount (CM) Low Velocity Center Mount (LVCM)	Air & Electric	115/1 208-230/1	CM: All ¹ LVCM: 050/075 ²	Stucco	89730201	
				White	89730202	
			LVCM: 100 ²	Stucco	89730205	
				White	89730206	
			LVCM: 130 to 340 ²	Stucco	89730209	
				White	89730210	
Medium Profile (MP)	Air	115-230/1	All	Stucco	89730301	
				White	89730302	
		460/1		Stucco	89730303	
				White	89730304	
	Electric	208-230/3	All	Stucco	89730305	
				White	89730306	
				Stucco	89730307	
		208-230/3 with >30A Heater ³		White	89730308	
				460/3	Stucco	89730309
					White	89730310
Large Unit Cooler (LUC)	Air	230-460/1	24" Fan	Plain Aluminum	89730401	
			30" Fan		89730402	
		230-575/3	24" Fan		89730403	
			30" Fan		89730404	
			30" Fan		89730405	
					89730406	
	Electric	230-460/1	24" Fan		89730407	
			30" Fan		89730408	
		208-230/3	24" Fan		89730409	
			30" Fan		89730410	
		460/3	24" Fan		89730411	
			30" Fan		89730412	
		575/3	24" Fan		89730413	
			30" Fan		89730414	
					89730415	
			89730416			

Note:

- Center Mount unit cooler models use 89730201 or 89730202 kit part numbers only.
- Low Velocity Center Mount unit cooler models are based on the capacity digits in the model number for the kit size and part number
- Medium Profile unit coolers have greater than 30 Amp draw with large defrost heaters use kit part number 89730307 and 89730308.
- intelliGen is not available for Low Profile models with 208-230/3/60 and 460/1/60.
- intelliGen is not available for Low Velocity Center Mount models with 460/1/60.

Notes:

Heatcraft Refrigeration Products, LLC
2175 West Park Place Blvd., Stone Mountain, GA 30087
www.heatcraftprd.com

Customer Service and Technical Support

Normal Business Hours – 8:00 AM – 8:00 PM EDT
(800) 321-1881

After Hours (after 5:00 PM EDT, weekends and holidays)
(877) 482-7238

Since product improvement is a continuing effort, we reserve the right to make changes in specifications without notice.

©2023 Heatcraft Refrigeration Products LLC

